

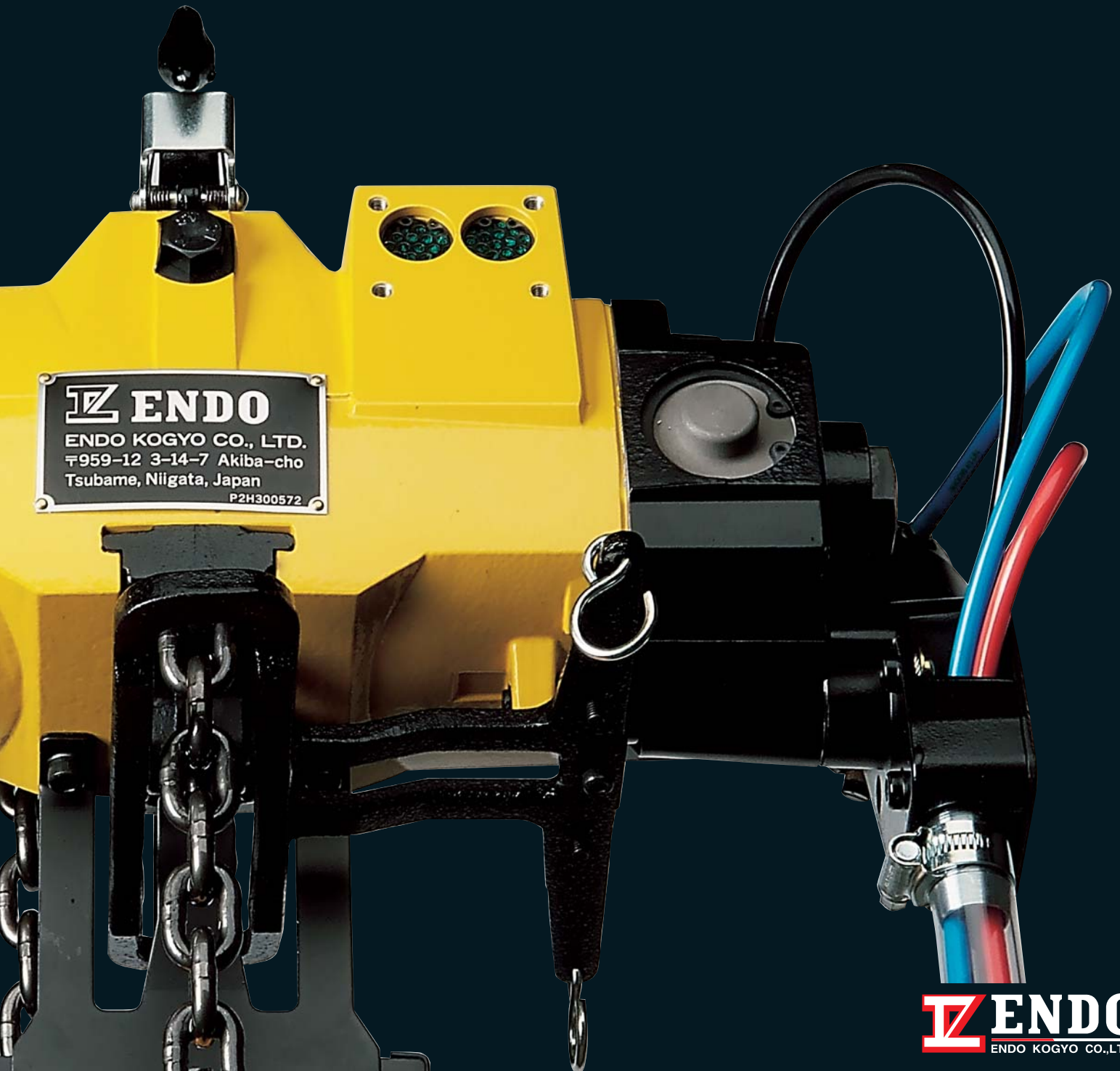

AIR HOIST







ENDO "AIR HOIST" SERIES



ENDO
ENDO KOGYO CO., LTD.
〒959-12 3-14-7 Akiba-cho
Tsubame, Niigata, Japan
P2H300572

ENDO high efficient air hoists achieve speedy and safe work.

Advantages;

-  **Small and compact body provides easy handling.**
-  **High-speed operation provided by ENDO air hoists serves the improved working efficiency to the work which requires considerable frequency.**
-  **Smooth and step less operation avails for precise works like Jig setting.**
-  **Non-step speed control is available. Operation speed depends on the pushing degree of the push buttons or the pulling degree of the control rope.**
-  **Easy installation. The air hoist works after hose connecting. No adjustment is required.**
 * Always make sure of air blow before connecting the hose with an air hoist. This is important to avoid the unexpected trouble of control valve etc.
-  **ENDO air motor realizes safe working condition against the work in the risk of explosion like the chemical factory.**



Structure of ENDO air hoist

The vane motor is applied to ENDO air hoists. Seven vanes are composed of one set of vanes and incorporated in rotor. These vanes are movable toward radius direction and moves in the biased cylinder receiving air pressure. The moving vanes move the rotor and finally lifting and lowering are realized.

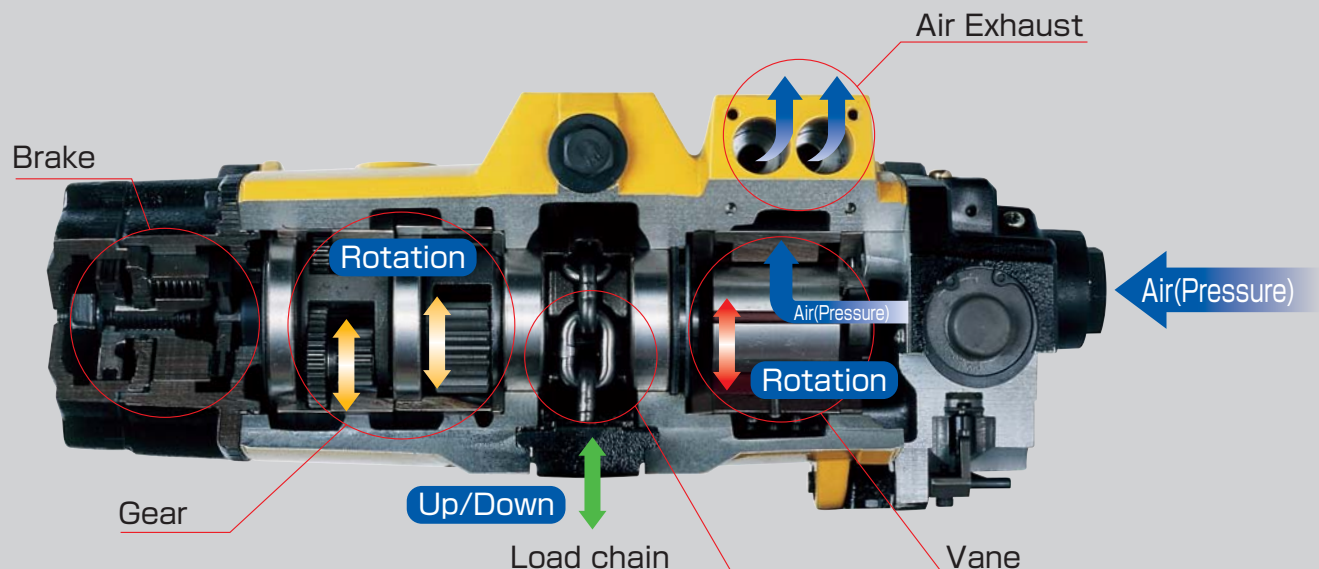

Explanation about speed control

Non-step speed control is available. Operation speed depends on the pushing degree of the push buttons or the pulling degree of the control rope.



EHW-60
EHW-120



EHW-60R
EHW-120R·AT



ATC



(EHL) PCS-1
(EHL) PCS-2



(EHL) Pull rope

ENDO air hoist speed control is associated with the accelerator of motor bicycle or car. Pushing degree / pulling degree controls the speed of lifting / lowering.

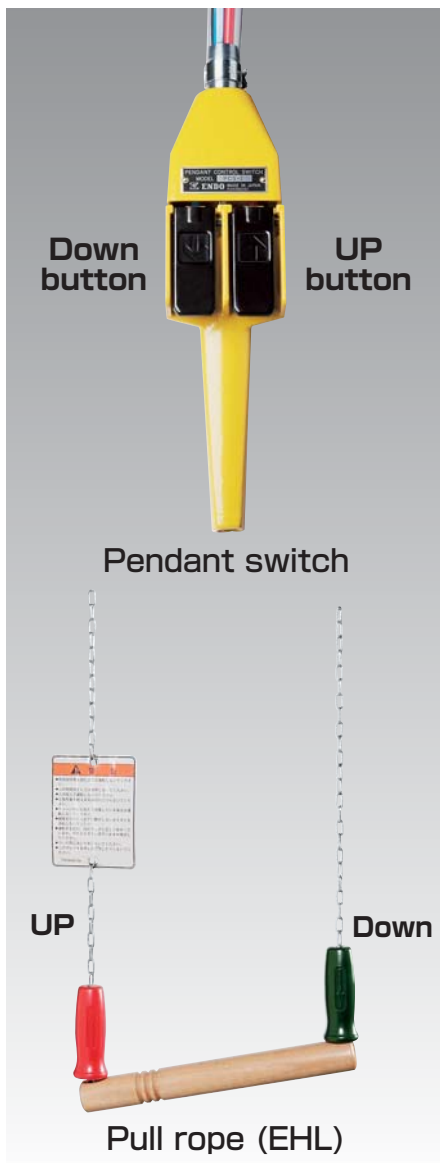

Pushing degree - [shallow]



Pulling degree - [shallow]

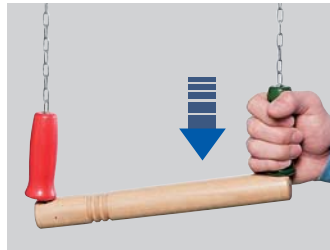

Pushing degree - [deep]



Pulling degree deep - [deep]

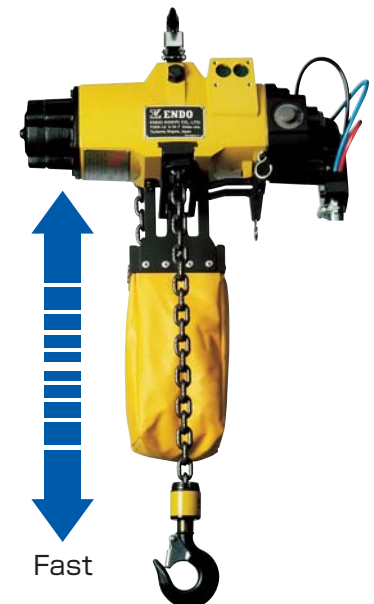
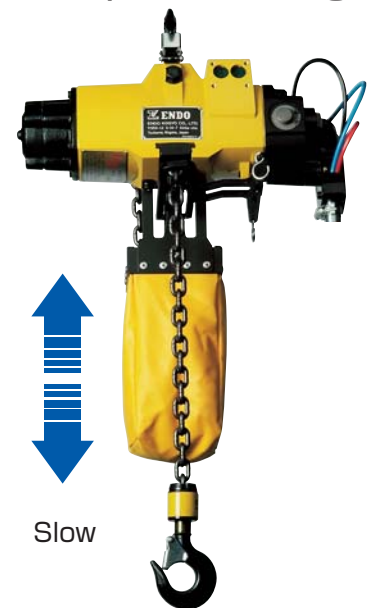
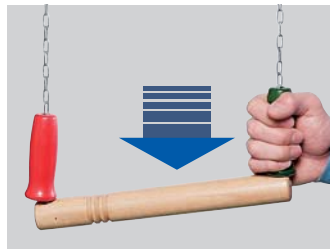

WIRE TYPE EHW / AH



Wire rope series

Features

1. Reduction gears are planetary gears which are small and light and can take large speed reduction ratio. Reduction gears are well heat-treated having adequate strength.
2. Control valve is engineered with spool valves of spring return in 2 positions and 3 ports. The valve works by controlling the lever switch connected with the spool.
3. The cone brake system is applied to the wire rope hoists. The durable cone brake connected with the control valve is integrated with the proper speed reduction mechanism at air motor, finally achieving the excellent control.
4. The reverse winding protection is incorporated in EHW air hoists series. When the wire rope is pulled out 1.9 m, the system makes the air motor stopped automatically. Safety working is provided.

EHW-60 EHW-120

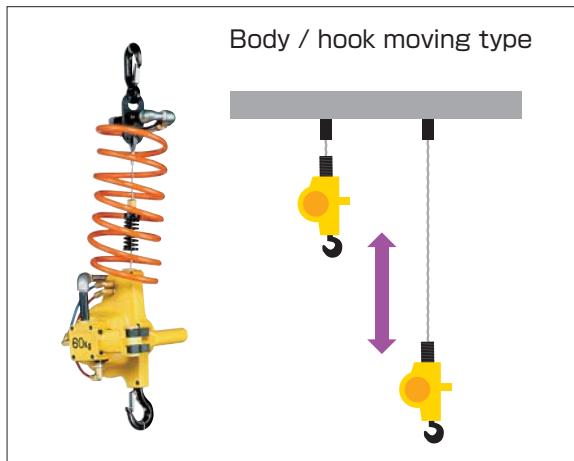

EHW-60R EHW-120R AH-250R

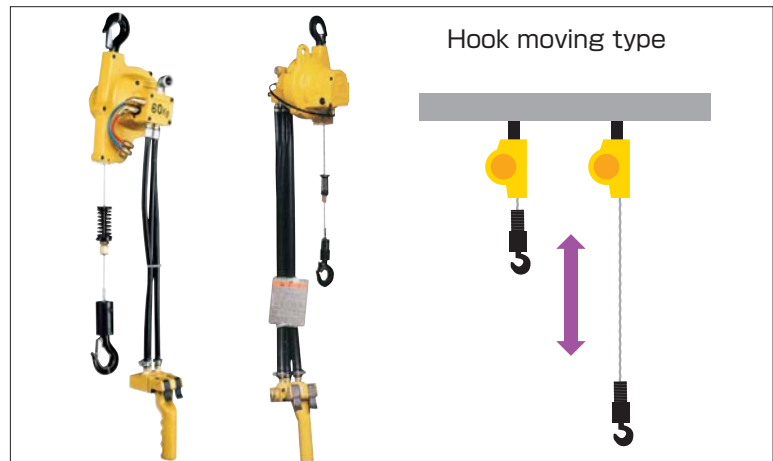

Specification

Model	Rated load kg	Stroke m	Air pressure MPa(kgf/cm ²)	Lifting speed m/min	Air consumption m ³ /min (normal)	Air inlet	Mass kg
EHW-60	60	1.9	0.4{4}	18.5	0.55	R,3/8	9.2
			0.5{5}	22.5	0.7		
			0.6{6}	26.0	0.88		
EHW-60R/EHW-60R-5	60	1.9	0.4{4}	18.5	0.55	Rc,3/8	9.5 (10.3)
			0.5{5}	22.5	0.7		
			0.6{6}	26.0	0.88		
EHW-120	120	1.9	0.4{4}	11.0	0.59	R,3/8	9.4
			0.5{5}	13.5	0.75		
			0.6{6}	16.0	0.93		
EHW-120R/EHW-120R-5	120	1.9	0.4{4}	11.0	0.59	Rc,3/8	9.7 (10.4)
			0.5{5}	13.5	0.75		
			0.6{6}	16.0	0.93		
AH-250R	160	2.5	0.4{4}	9.0	0.75	Rc,1/2	18.2
	200		0.5{5}	10.0	0.92		
	250		0.6{6}	11.0	1.1		

Note) Application; Indoor -10°C~+50°C (Temperature) () indication in Mass means EHW-XX-5 type.

EHW-60

EHW-120



Wire rope type



Button control



Reverse winding protection



Air motor trolley



Plain trolley



II 2 G / D II BT 5 (X)

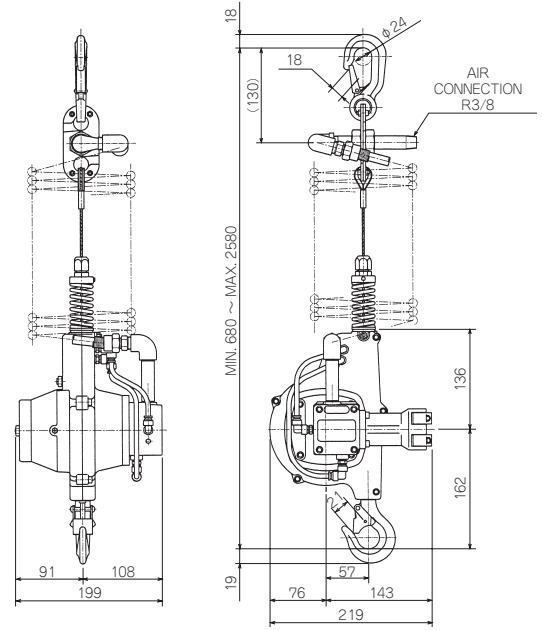

EHW-60R

EHW-120R



Wire rope type



Button control



Reverse winding protection



Air motor trolley



Plain trolley



II 2 G / D II BT 5 (X)

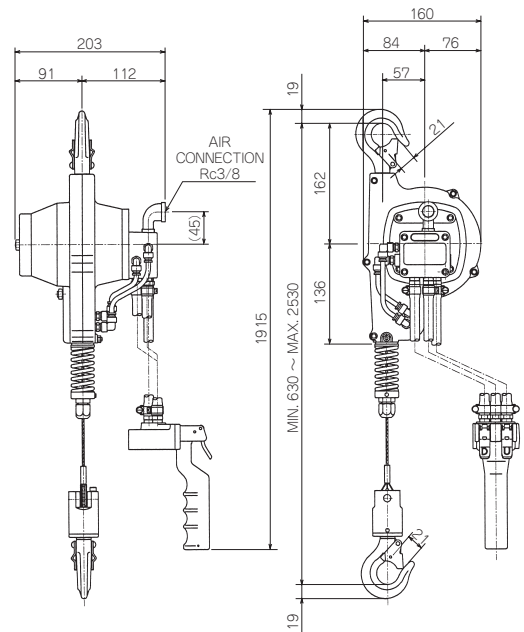

AH-250R



Wire rope type



Button control



Air motor trolley

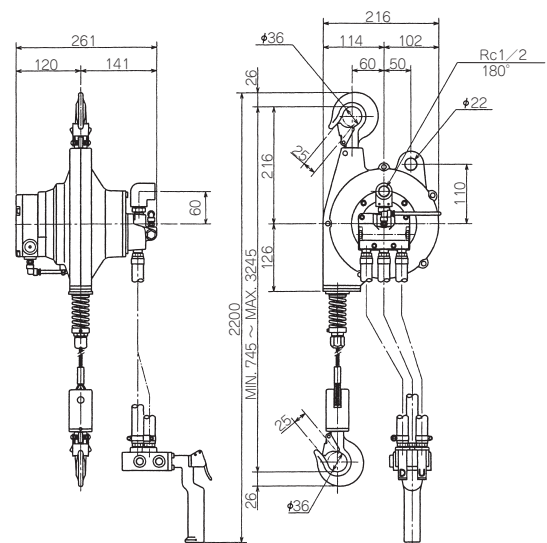

Note

1. Install a filter and lubricator to the hoist as close as possible.
2. Both of cable extension and stroke extension are not available on EHW series and AH-250R.
3. Chain hoists are recommended for the frequent operation.

Load chain series

ENDO chain hoists employ the surface hardened load chain with T, Grade 8.

Specification

Model	Rated load t	Stroke m	Air pressure MPa(kgf/cm ²)	Lifting speed m/min	Air consumption m ³ /min (normal)	Chain size × fall	Air inlet	Mass kg
AT-60K AT-60K-5	60kg	3	0.4 {4}	16.5	0.52	4.0 × 1	Rc 3/8	12.3 (13.0)
			0.5 {5}	20.0	0.67			
			0.6 {6}	23.5	0.85			
ATC-60K ATC-60K-5	60kg	2	0.4 {4}	14.0	0.45	4.0 × 1	Rc 3/8	14.3
			0.5 {5}	17.0	0.58			
			0.6 {6}	20.0	0.68			
AT-125K AT-125K-5	125kg	3	0.4 {4}	10.0	0.55	4.0 × 1	Rc 3/8	12.5 (13.2)
			0.5 {5}	12.0	0.71			
			0.6 {6}	14.5	0.90			
ATC-125K ATC-125K-5	125kg	2	0.4 {4}	6.5	0.42	4.0 × 1	Rc 3/8	14.5
			0.5 {5}	10.5	0.55			
			0.6 {6}	12.0	0.65			
EHL-025TS	1/4	3	0.4 {4}	12.0	0.9	6.3 × 1	Rp 1/2	18.7
			0.5 {5}	16.0	1.3			
			0.6 {6}	18.0	1.6			
EHL-05TS	1/2	3	0.4 {4}	7.5	0.95	6.3 × 1	Rp 1/2	18.7
			0.5 {5}	9.0	1.3			
			0.6 {6}	10.5	1.65			
EHL-098TW	980kg	3	0.4 {4}	3.7	0.95	6.3 × 2	Rp 1/2	24.2
			0.5 {5}	4.5	1.3			
			0.6 {6}	5.2	1.65			
EHL-1TW	1	3	0.4 {4}	3.7	0.95	6.3 × 2	Rp 1/2	24.2
			0.5 {5}	4.5	1.3			
			0.6 {6}	5.2	1.65			
EHL-1TS	1	3	0.4 {4}	4.0	1.0	7.1 × 1	Rp 1/2	34.0
			0.5 {5}	5.2	1.4			
			0.6 {6}	6.0	1.8			
EHL-2TW	2	3	0.4 {4}	2.0	1.0	7.2 × 2	Rp 1/2	42.0
			0.5 {5}	2.6	1.4			
			0.6 {6}	3.0	1.8			
EHL-3TS	3	3	0.4 {4}	2.0	1.75	12.5 × 1	Rp 3/4	75.0
			0.5 {5}	2.6	2.47			
			0.6 {6}	3.0	3.14			
EHL-6TW	6	3	0.4 {4}	1.0	1.75	12.5 × 2	Rp 3/4	96.0
			0.5 {5}	1.3	2.47			
			0.6 {6}	1.5	3.14			

Note) ENDO air hoists are available for only indoor, with temperature of -10°C ~ +50°C. The figures () indicate AT-60K-5 and AT-125K-5.

AT.ATC SERIES

AT-60K

AT-125K



Chain type



Button control



Chain extension available



Air motor trolley (On request)



Plain trolley (On request)

Ex II 2 G / D IIB T 5 (X)

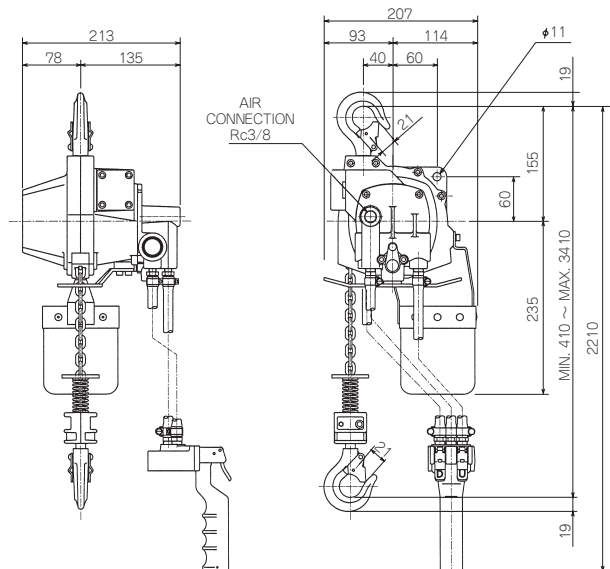

ATC-60K

ATC-125K



Chain type



Button control



Air motor trolley
(On request)



Plain trolley
(On request)



II 2 G / D II BT 5 (X)

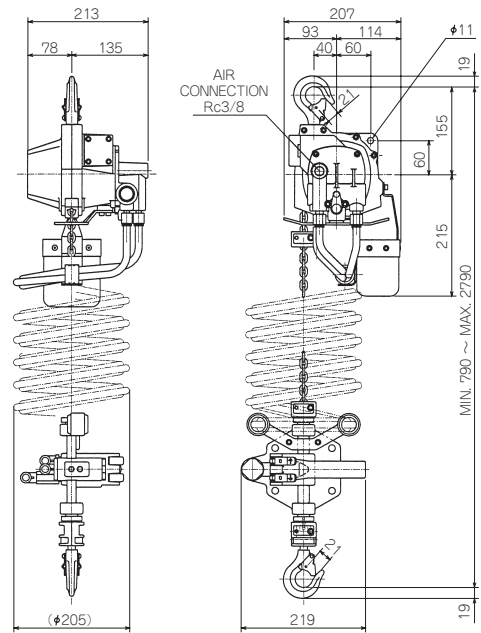

EHL SERIES

EHL-025TS

EHL-05TS



Chain type



Pendant switch
available



Chain extension
available



Air motor trolley
(On request)



Over load protector
(for EHL-05TS)
(On request)



II 2 G / D II BT 5 (X)

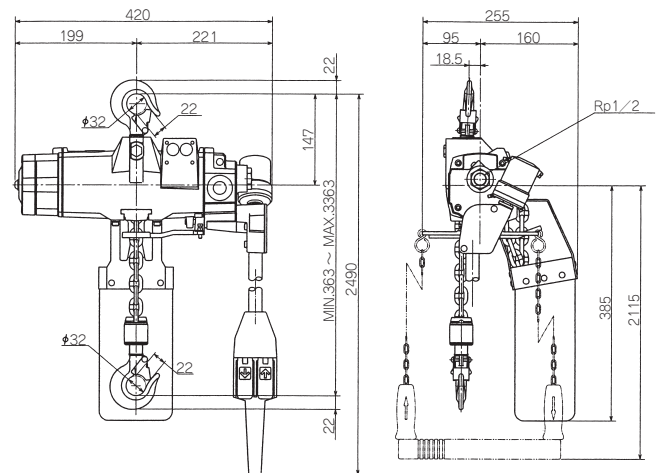

EHL-098TW

EHL-1TW



Chain type



Pendant switch
available



Chain extension
available



Air motor trolley
(On request)



Over load protector
(On request)



II 2 G / D II BT 5 (X)

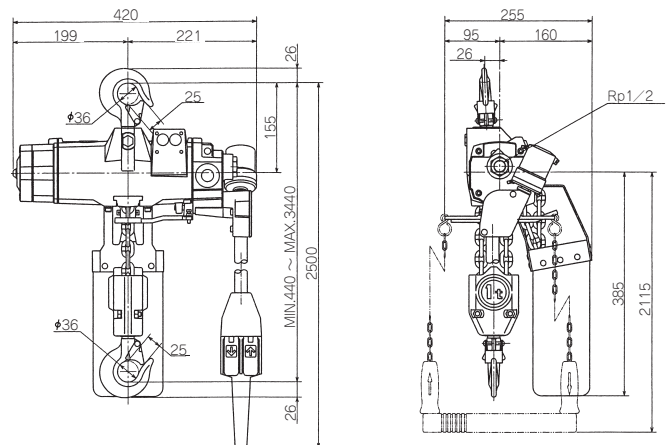

*Spheroidal graphite cast iron body is available for EHL-1TW on request.

Note 1. Install a filter and lubricator to the hoist as close as possible.

EHL-1TS



Chain type



Pendant switch available



Chain extension available



Air motor trolley (On request)



Over load protector (On request)

Ex II 2 G / D I I B T 5 (X)

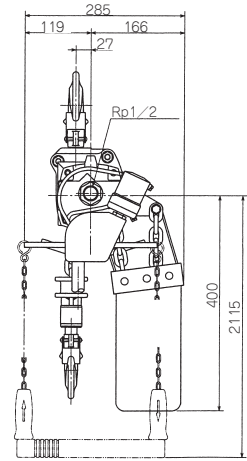
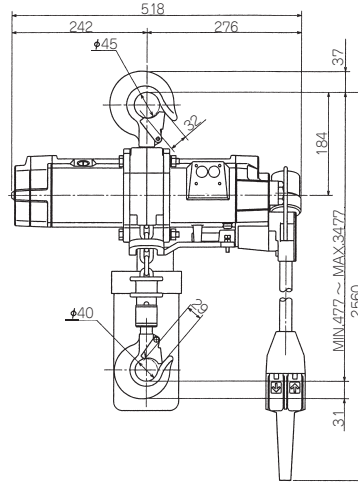

EHL-2TW



Chain type



Pendant switch available



Chain extension available



Air motor trolley (On request)



Over load protector (On request)

Ex II 2 G / D I I B T 5 (X)

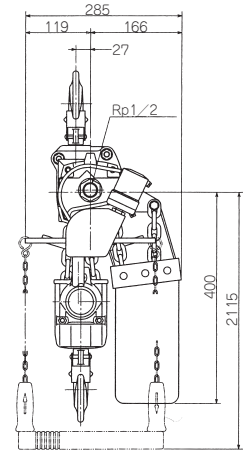
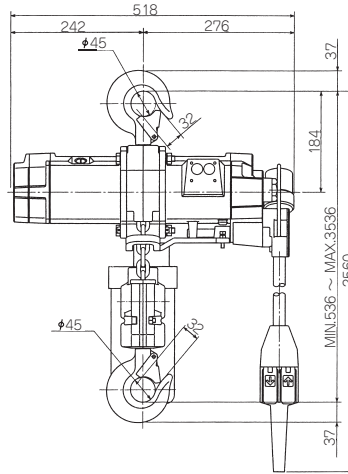

EHL-3TS



Chain type



Pendant switch available



Chain extension available



Air motor trolley (On request)





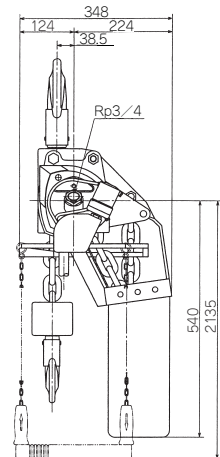
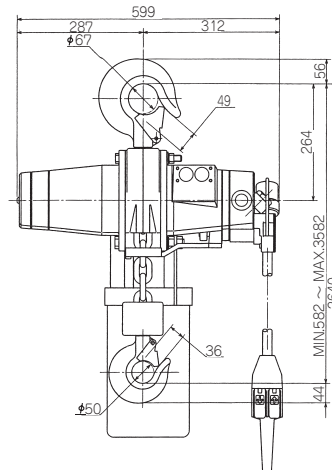

Over load protector (On request)

Ex II 2 G / D I I B T 4 (X)



- Note**
1. Install a filter and lubricator to the hoist as close as possible.
 2. Chain hoists are recommended for the frequent operation.

EHL-6TW

-  Chain type
-  Pendant switch available
-  Chain extension available
-  Air motor trolley (On request)
-  Over load protector (On request)

 II 2 G / D II BT 4 (X)

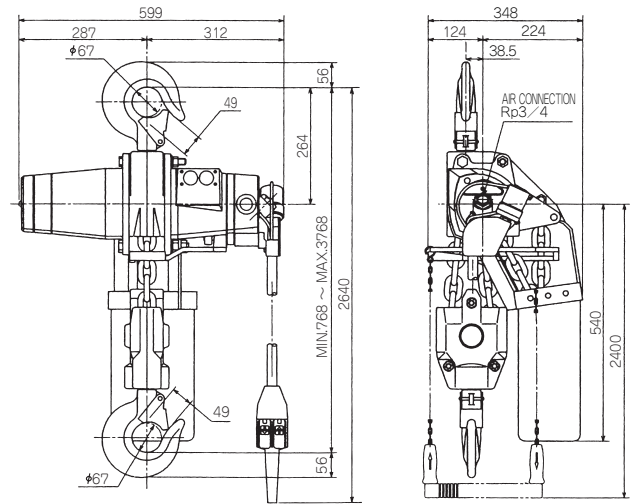

availability for Small capacity hoists

The under mentioned models have an emergency stop and CE available.

-  EHW-60R-5
-  EHW-120R-5
-  AT-60K-5
-  AT-125K-5
-  ATC-60K-5
-  ATC-125K-5

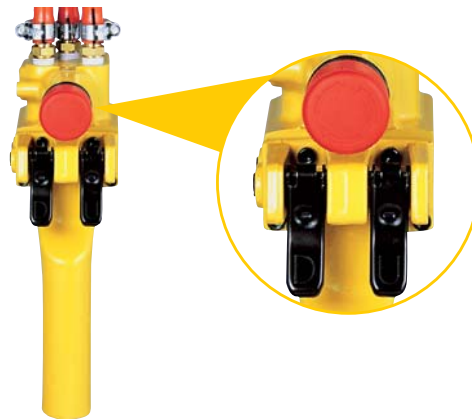

EHW-60R-5 / EHW-120R-5
AT-60K-5 / AT-125K-5

ATC-60K-5 / ATC-125K-5

availability for EHL series

Control type Model name	Pull rope	PCS-1	PCS-1B	PCS-2	PCS-2B	Remark
EHL-025TS	○	×	○	—	—	
EHL-05TS	○	×	○	—	—	
EHL-098TW	○	×	○	—	—	
EHL-1TW	○	×	○	—	—	Overload protector is required
EHL-1TS	○	—	—	×	○	Overload protector is required
EHL-2TW	○	—	—	×	○	Overload protector is required
EHL-3TS	○	—	—	×	○	Overload protector is required
EHL-6TW	○	—	—	×	○	Overload protector is required

○ mark : CE available × mark : CE not available — : not applicable "see page 9"

Note 1. Install a filter and lubricator to the hoist as close as possible.

Accessories

Pendant switch

- Pendant switch PCS-1 / PCS-2
 - Pendant switch PCS-1B / PCS-2B
(Emergency stop included; CE available)
- * PCSs are available for only EHL hoists

Model	Available hoists	Mass (kg)
PCS-1	EHL-025TS EHL-05TS EHL-1TW	2.3
PCS-1B	EHL-098TW	2.3
PCS-2	EHL-1TS EHL-2TW EHL-3TS	2.7
PCS-2B	EHL-6TW	2.7

Note) Max. hose extension is up to 6m
(total lengths of hose must be less than 8m).



PCS-1/2



PCS-1B/2B



Cleaner set

This device is available for eliminating noisy volume and gathering the exhausted oil from the exhaust hole. The device contributes to clean environment.

Parts Number	Available hoist	Mass (kg)
LHP001343	EHL-025TS, EHL-05TS, EHL-098TW, EHL-1TW	1.0
LHP001388	EHL-1TS, EHL-2TW	1.0
LHP001389	EHL-3TS, EHL-6TW	1.6



Overload protector

Model	Available hoist	Mass (kg)	Model	Available hoist	Mass (kg)
OP-05TS	EHL-05TS	2.0	OP-2TW	EHL-2TW	6.2
OP-1TW	EHL-1TW	2.2	OP-3TS	EHL-3TS	22.0
OP-1TS	EHL-1TS	6.2	OP-6TW	EHL-6TW	22.0

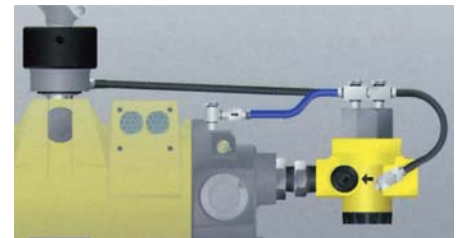

OP-05TS

Other option available

Stainless steel load chain

Due to the low breaking load of this type of chain, the nominal capacity of EHL-1TS, EHL-2TW would be reduced 20%. (800 kg and 1600 kg each). For 3 ton and 6 ton hoist, No stainless chain is available.

Chain buckets

ENDO supplies a chain bucket for the undermentioned chain lengths.

Model / chain lengths	6 m	10 m	12 m	20 m
AT-60K / AT-125K	○		△	△
EHL-025TS / EHL-05TS	○		△	△
EHL-098TW / EHL-1TW	○		△	△
EHL-1TS / EHL-2TW	○		△	△
EHL-3TS / EHL-6TW	○	△		

Note) 1.○ mark means a standard bucket.
2.△ mark means an optional bucket.
3.When you need the bucket capable of the other chain lengths,contact our distributor or maker.

Air motor trolley - MTH series -

The ENDO air motor trolley can work at the chemical factory or in hazard condition safely so that power source is the compressed air.

Stepless speed control is available. The working efficiency will be improved at frequent operation because high speed operation is achieved as well as delicate operation.

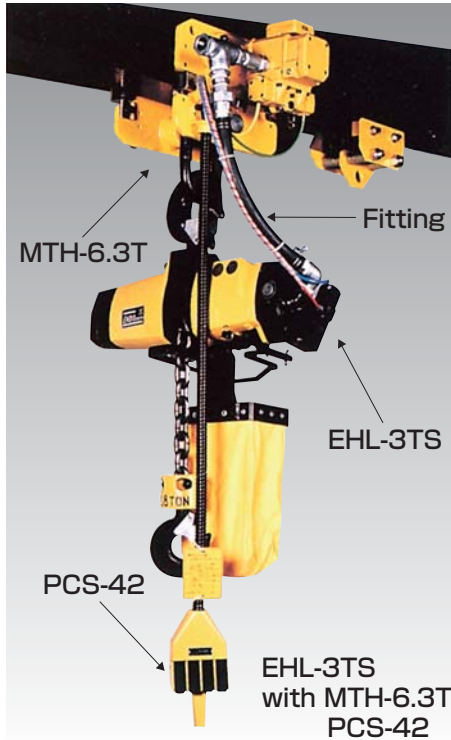

4 direction control with PCS-42

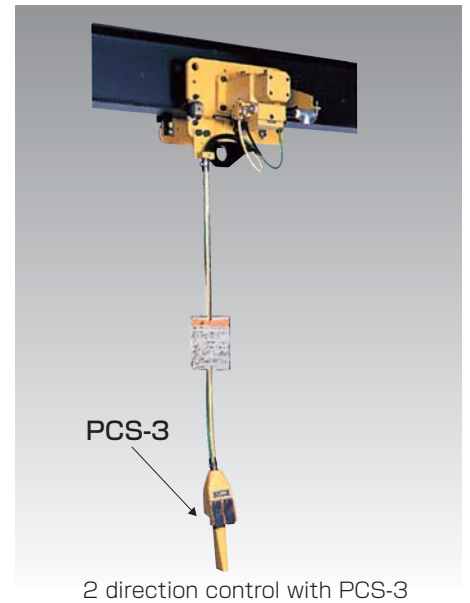

Control choice

Pendant switch

Model	Available AIR MOTOR TROLLEY	Mass (kg)
PCS-3	MTH-1T-5, MTH-2T-5, MTH-6.3T	2.3
PCS-41	MTH-1T-5 + available EHL hoist	3.2
PCS-41B	MTH-1T-5 + available EHL hoist	3.2
PCS-42	MTH-2T-5 / MTH-6.3T + available EHL hoists	3.6
PCS-42B	MTH-2T-5 / MTH-6.3T + available EHL hoists	3.6

Note) PCS-3 is for traverse only.
"B" indicates "Emergency stop equipped".

Specification

Model	Capacity t	Air pressure MPa {kgf/cm ² }	Travelling speed m/min	Air consumption m ³ /min (normal)	Available beam width mm	Min.radius for curve mm	Air inlet Rc	Mass kg
MTH-1T-5	1	0.4 {4}	20	0.55	75	3500	1/2	35.0
		0.5 {5}	25	0.6				
		0.6 {6}	28	0.65	100 · 125	800		
MTH-2T-5	2	0.4 {4}	16	1.05	125 · 150	1000	1/2	63.0
		0.5 {5}	17	1.3				
		0.6 {6}	18	1.6				
MTH-6.3T	6.3	0.4 {4}	17	1.05	150 · 175 · 190	2500	3/4	127.0
		0.5 {5}	18	1.3				
		0.6 {6}	19	1.6				

Note) Four push button control (4 direction) is available as well as two push button control (2 direction). It depends on the customer request. Low head room application is available on request.

Corresponding Table - Air hoist / Air motor trolley -

Model	EHL-025TS	EHL-05TS	EHL-098TW	EHL-1TW	EHL-1TS	EHL-2TW	EHL-3TS	EHL-6TW
MTH-1T-5	○	○	○	○				
MTH-2T-5					○	○		
MTH-6.3T							○	○

MTH-1T-5 with PCS-3



Pendant switch
(traverse)

PCS-3



4 direction pendant
control available

PCS-41

PCS-41B

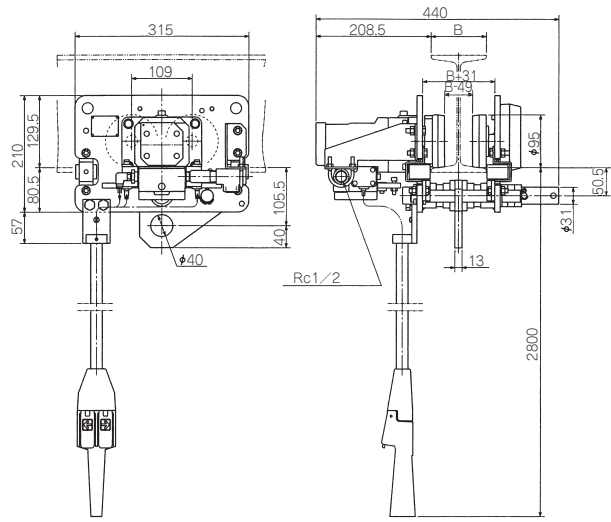

MTH-2T-5 with PCS-3



Pendant switch
(traverse)

PCS-3



4 direction pendant
control available

PCS-42

PCS-42B

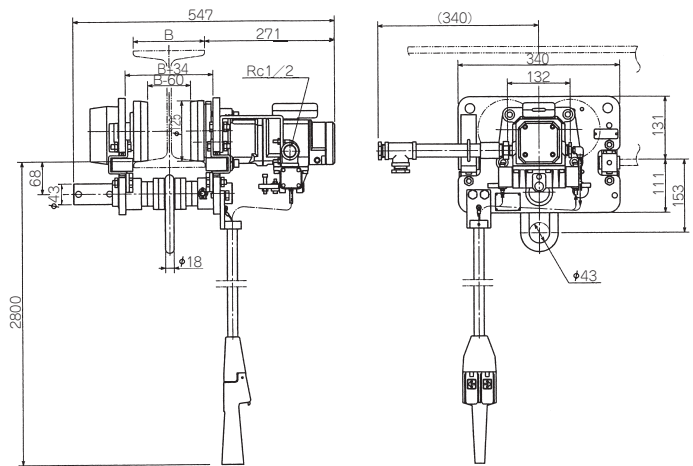

MTH-6.3T with PCS-3



Pendant switch
(traverse)

PCS-3



4 direction pendant
control available

PCS-42

PCS-42B

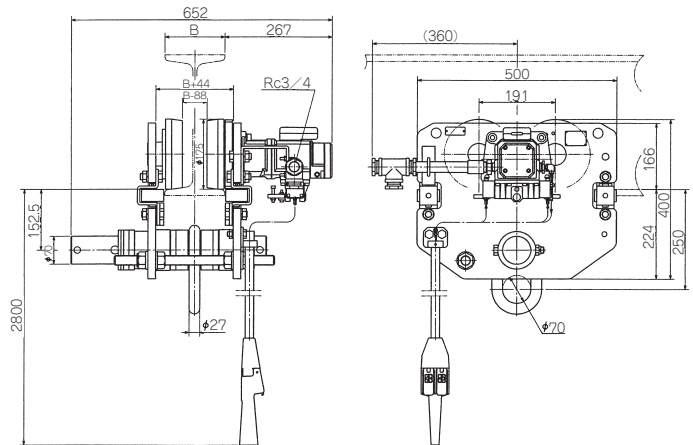

Note 1. Install a filter and lubricator to the hoist as close as possible.

ENDO KOGYO CO., LTD.

Head Office 3-14-7, Akibacho, Tsubame, Niigata, Japan
TEL.0256-62-5131 FAX.0256-62-5772

Tokyo Office Tanaka Bldg.,2F, 12, Kanda Higashimatushita-cho, Chiyodaku, Tokyo, Japan
TEL.03-5295-3711 FAX.03-5295-3717

Osaka Office Daito Bldg.,3F, 3-14, Saiwaicho 2-chome, Naniwaku, Osaka, Japan
TEL.06-6568-1571 FAX.06-6568-1573

Kyusyu Office Bunki Bldg.,3F, 11-15, Hakataekihigashi 3-chome, Hakataku, Fukuoka, Japan
TEL.092-412-5281 FAX.092-412-5280

URL <http://www.endo-kogyo.co.jp>

※Items shown in this catalogue are subject to change without notice.

※Please note we no have responsibility for missing and fault on the printing.

EC-76 2008.08.3000 ©